

MG-FLEX 300

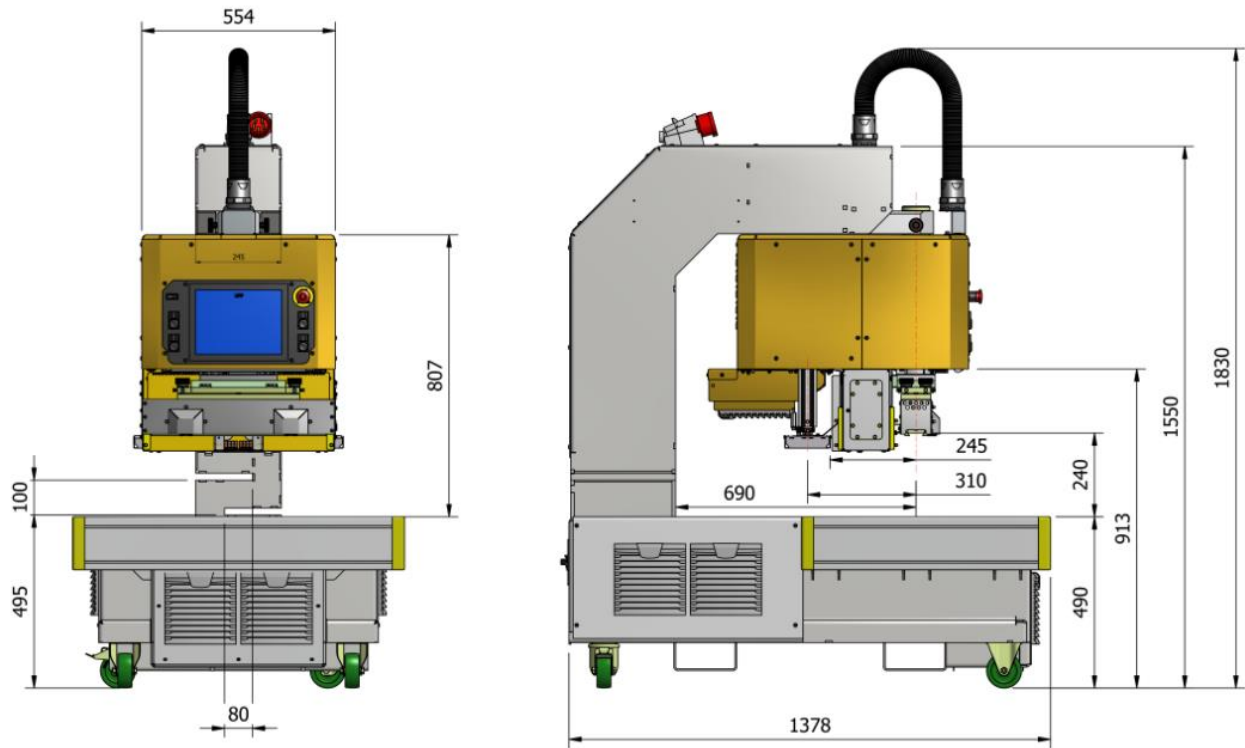

TECHNICAL SPECIFICATIONS

Power requirement – free running	1,3 kW
Power requirement – max/hour	5,5 kW
Emitted power HF maximum on electrode	8 kW
Main fuse – type D	32 A
Standard voltage	3 x 400 V 50 Hz / 60 Hz + earth + neutral
Working frequency	27,12 MHz \pm 0,6 %
Transmitting tube - type	ITL 5-1
Transmitting tube - cooling	Air-cooled
Flash protection	Thyristor controlled
Pressure	Maximum 700 kg at minimum 9 bar / 130 psi
Maximum air consumption - automatic	86 l/min
Daylight (with a 45 mm high electrode)	190 mm
Pneumatic press with automatic pressure protection system	PSK, 2-Hand start
Weight of the machine	580 kg
Max. welding surface each working cycle	300 cm ²
Max. weldable electrode width	350 mm
Computer with 12" touch-screen	Forsstrom™ industrially developed, HF-classified computer
Free space behind the electrode	690 mm
Available accessories	Built-in compressor, stand, foot pedal